

Meistergram®
THE PERSONALIZATION PEOPLE™

M800 SERIES

USER MANUAL

**PARTS IDENTIFICATION
M800 MACHINE**

PARTS IDENTIFICATION: M800

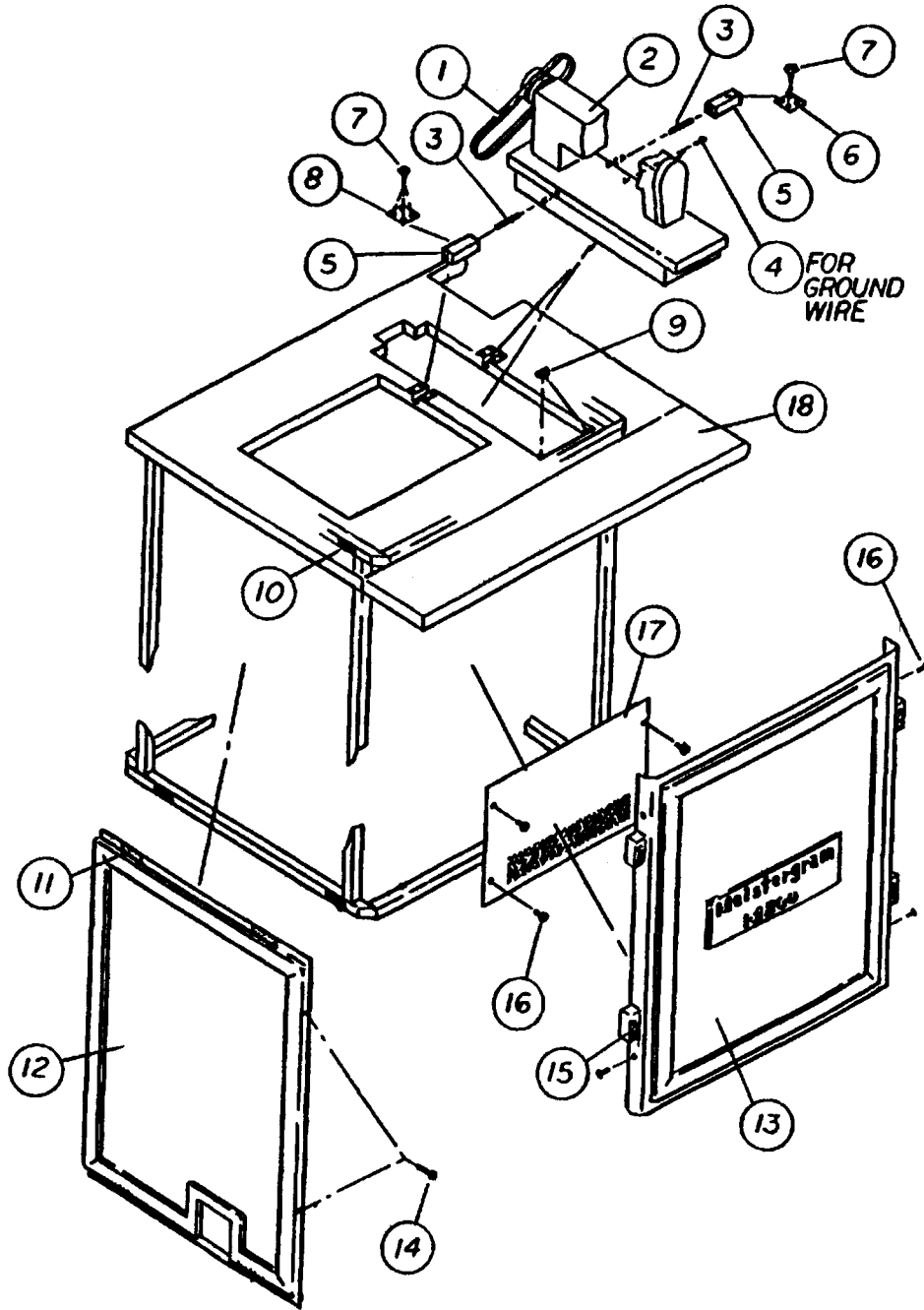

Frame Assembly 1 - fig. 1

PARTS IDENTIFICATION: M800**FRAME ASSEMBLY**

<u>ITEM</u>	<u>QUANTITY</u>	<u>PART NO.</u>	<u>DESCRIPTION</u>
1	1	P820042	V-BELT
2	1	ZP515000	SEWING HEAD ASSY.
3	2	P514003	HEAD HINGE PIN
4	1	P840188	#6-32x1/2 SLOTTED PAN HEAD SCREW
5	2	P840914	HEAD HINGE SUPPORT
6	1	P520024	FRONT HEAD HINGE PLATE
7	8	P840148	#6-32x3/8 PHILLIPS FLAT HEAD SCREW
8	1	P520022	BACK HEAD HINGE PIN PLATE
9	2	P520827	DIE CUT COVER PAD
10	1 ft. 4"	9P520007	ADHESIVE BACK LOOP FASTENING
11	1 ft. 4"	9P520005	ADHESIVE BACK HOOK FASTENING
12	1	P570008	REAR PANEL
13	2	P570004	RIGHT AND LEFT SIDE PANELS
14	8	P620083	#6x1/2 PHILLIPS DECT. HEAD SCREW
15	8	P620011	TINNERMAN CLIP (for item #14)
16	4	P840203	#8-32x1/2 SELF TAP HX HEAD SCREW
17	1	P670835	ELEC. ENCLOSURE COVER PLATE
18	1	ZP570900	TABLE TOP ASSEMBLY

PARTS IDENTIFICATION: M800

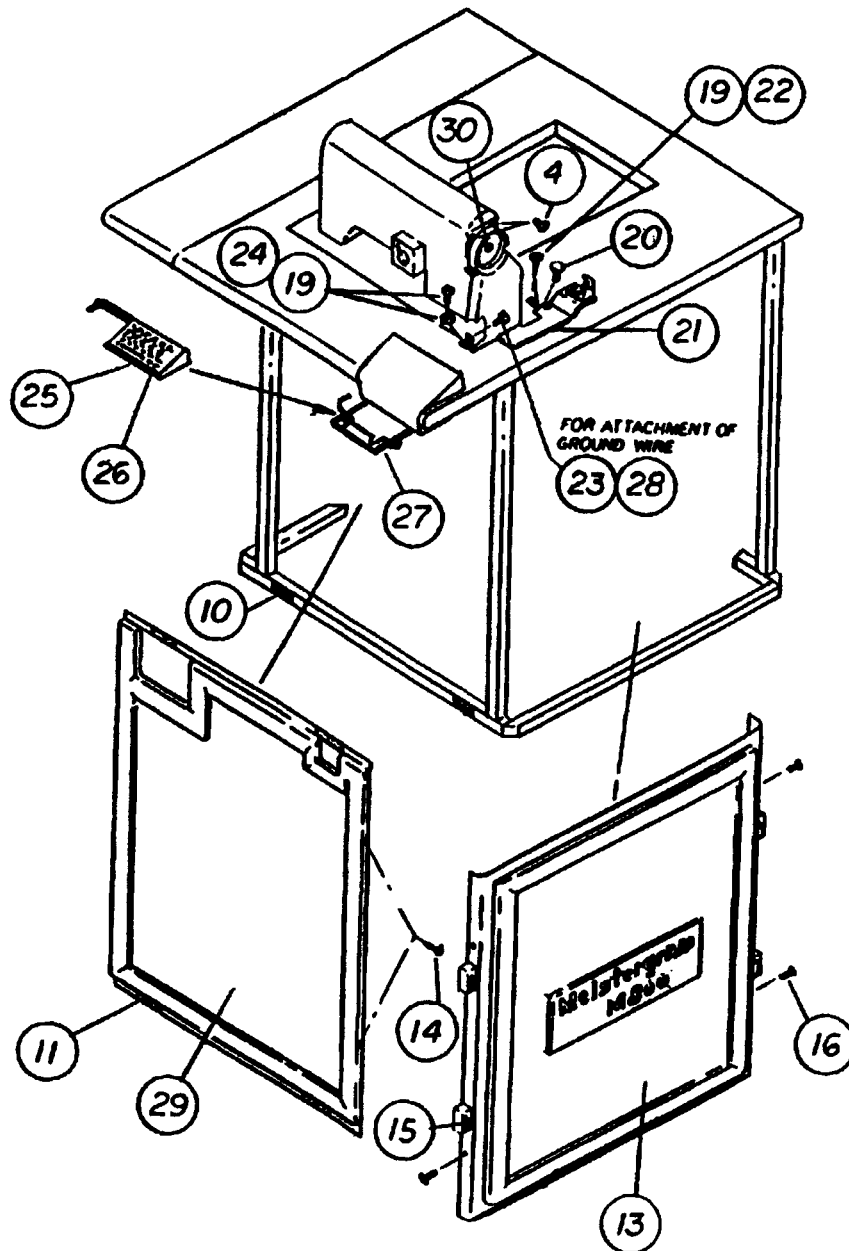

Frame Assembly 2 - fig. 2

PARTS IDENTIFICATION: M800**FRAME ASSEMBLY**

ITEM	QUANTITY	PART NO.	DESCRIPTION
4	2	P840189	6-32x1/2 SLOTTED PAN HEAD SCREW
10	1 ft. 4"	9P520007	ADHESIVE BACK LOOP FASTENING
11	1 ft. 4"	9P520005	ADHESIVE BACK HOOK FASTENING
13	2	P570004	RIGHT AND LEFT SIDE PANELS
14	8	P670083	#6x1/2 DECT. PHILLIPS HEAD SCREW
15	8	P620011	TINNERMAN CLIP
16	12	P840203	#8-32x1/2 HEX HEAD SCREW
19	2	P840305	#7x3/4 SLOTTED RND HD BLK. WOOD SCREW
20	1	P220501	TEMPLATE HOLDER THUMBSCREW
21	1	ZP520300	BELT GUARD/BOBBIN WINDER ASSEMBLY
22	1	P520327	GUARD STOP BOBBIN WINDER
23	1	P840415	#6-32x1/4 SLOTTED PAN HEAD SCREW
24	1	P840513	#6 WASHER STAMPED NYLON
25	1	P670020	KEYBOARD
26	1	P896002	KEYBOARD DECAL
27	1	P670010	KEYBOARD RACK
28	1	P820511	#6 RING LUG 16-14 AWG.
29	1	P570006	FRONT PANEL

PARTS IDENTIFICATION: M800

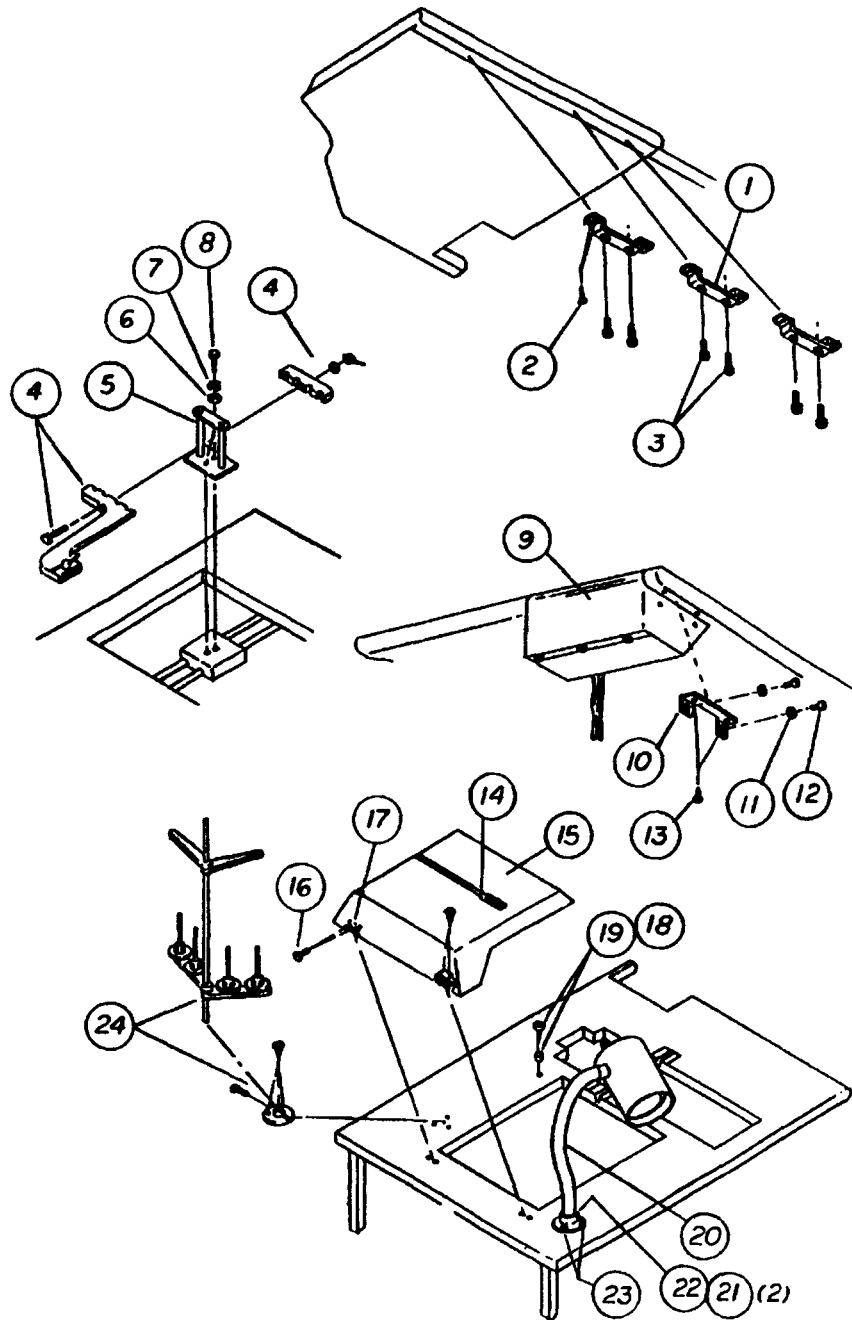

Frame Assembly - fig. 3

PARTS IDENTIFICATION: M800**FRAME ASSEMBLY**

ITEM	QUANTITY	PART NO.	DESCRIPTION
1	3	P570910	TABLE LEAF BRACKET
2	12	P840317	#10x1/4 PHILLIPS WOOD SCREW
3	6	P840052	1/4x20x1/2 SOCKET HEAD MACHINE SCREW
4	1	ZP520500	HOOP ARM ASSEMBLY
5	1	P520501	HOOP ARM BASE
6	2	P840561	5/16 FLAT WASHER
7	2	P840582	5/16 LOCKWASHER
8	2	P840601	5/16-18x3/4 HX. HEAD BOLT
9	1	ZP80500	CONTROL CONSOLE ASSEMBLY
10	2	P670910	CONTROL CONSOLE MANAGEMENT BRACKET
11	4	P840572	#10 SLIT LOCKWASHER
12	4	P840420	#10-32x3/8 PAN HEAD MACHINE SCREW
13	15	P840305	#7x3/4 WOOD SCREW
14	1	P896008	PANTO-LID DECAL
15	1	P570915	PANTOGRAPH COVER
16	4	P849642	POP RIVET 3/16x3/8
17	2	P590011	PANTOGRAPH COVER HINGE
18	1	P840905	RUBBER STOP 3/8x1/4
19	1	P840302	#4x3/8 WOOD SCREW
20	1	ZP670950	LAMP-CONNECTOR ASSEMBLY
21	1	P840432	#10-32x2 SLOTTED PAN HEAD SCREW
22	2	P840740	#10x32 HEX NUT
23	2	P840313	#10x3/4 PHILLIPS
24	1	P520030	THREAD STAND ASSEMBLY

PARTS IDENTIFICATION: M800

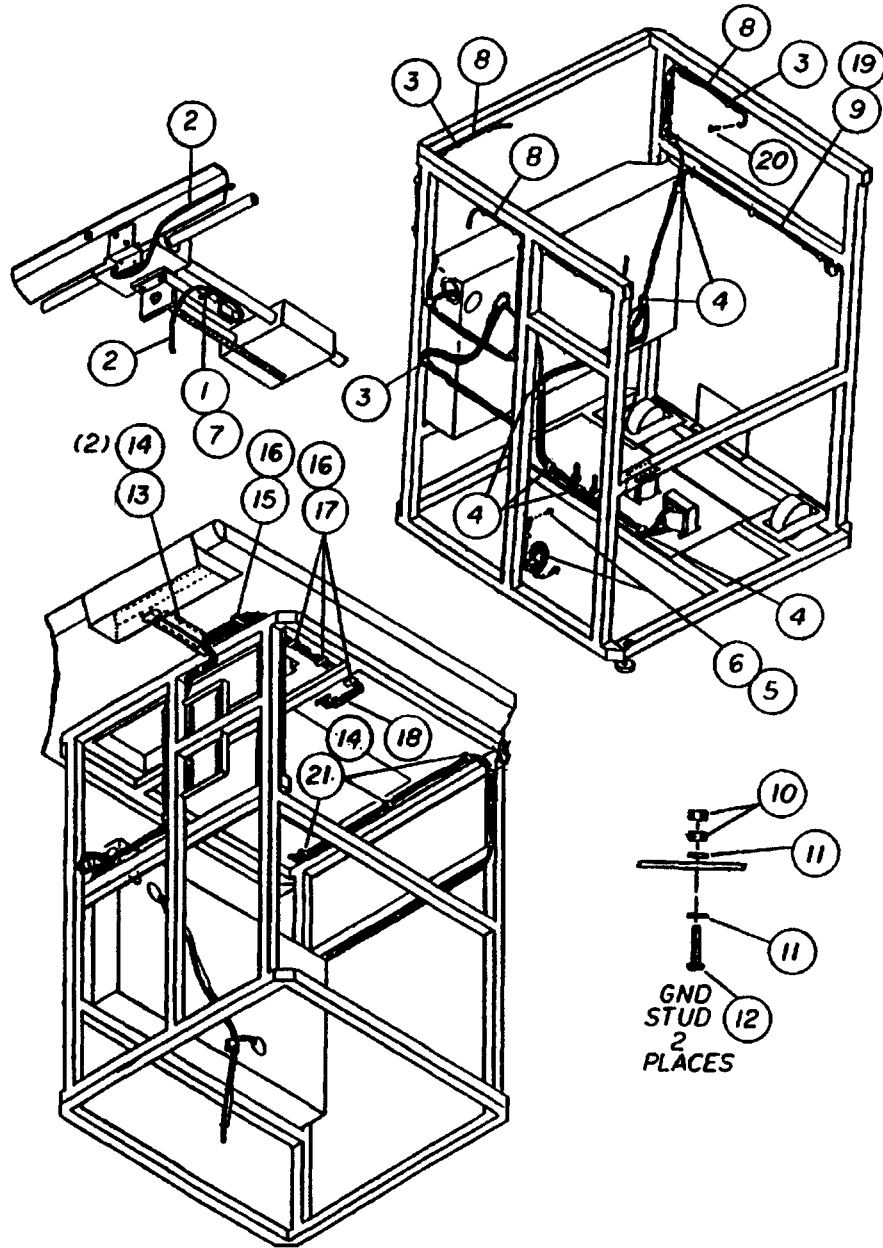

Frame Assembly 4 - fig. 4

PARTS IDENTIFICATION: M800**FRAME ASSEMBLY**

ITEM	QUANTITY	PART NO.	DESCRIPTION
1	1	P620105	NYLON STANDOFF
2	1	P580740	LIMIT SWITCH HARNESS
3	32	P530237	DART-TIE
4	6	P670911	STICK ON CABLE CLAMP
5	1	P840520	#8 FLAT WASHER
6	1	P840203	8-32x1/2 SELF TAPPING SCREW
7	6	P312037	TY-RAP
8	1	P580742	SYSTEM GROUND HARNESS
9	1	P680743	LAMP CORD
10	4	P840742	HEX BRASS NUT 10-32
11	4	P840535	#10 BRASS FLAT WASHER
12	2	P840126	10-32x3/4 PAN HEAD SCREW
13	1	P570052	TABLE MTG CABLE GUIDE
14	3	P840305	#7x3/4 WOOD SCREW
15	1	P320024	LARGE RIBBON CABLE CLAMP
16	6	P840347	#6x1/2 FLAT HEAD WOOD SCREW
17	8	P520109	RIBBON CABLE CLAMP
18	1	P680745	HEAD INTERFACE RIBBON CABLE
19	1	P580726	LAMP CORD GND
20	1	P840150	6-32x1/4 PHILLIPS SCREW
21	3	P820059	CABLE CLAMP

PARTS IDENTIFICATION: M800

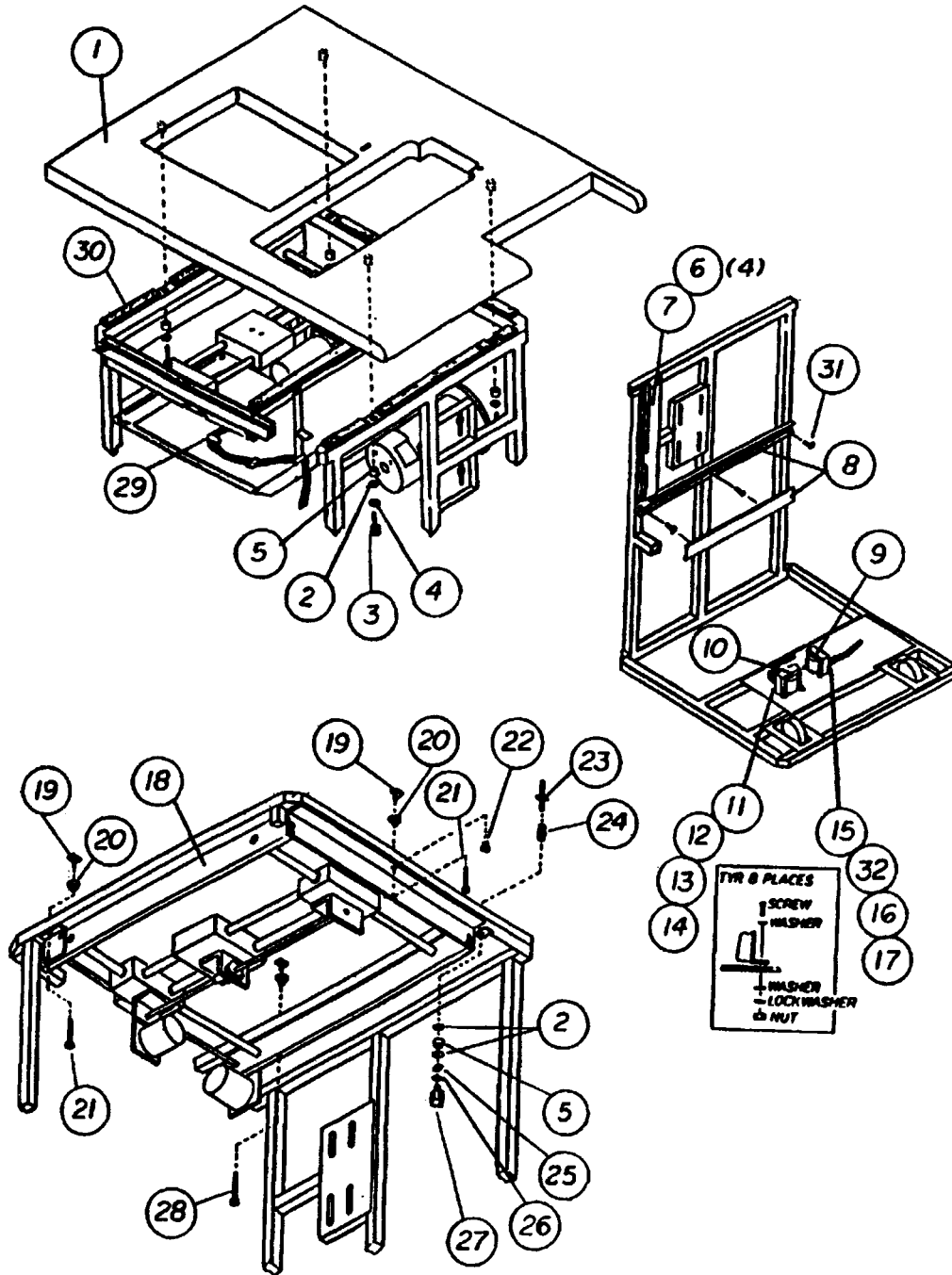

Frame Assembly 5 - fig. 5

PARTS IDENTIFICATION: M800**FRAME ASSEMBLY**

ITEM	QUANTITY	PART NO.	DESCRIPTION
1	1	P570820	TABLE TOP
2	6	P840540	1/4 FLAT WASHER
3	4	P840059	1/4-20x2 1/2 SOCKET HEAD
4	4	P840580	1/4 SPLIT LOCKWASHER
5	5	P840914	RUBBER GROMMET
6	4	P840629	POP RIVET
7	1	P520049	CABLE GUIDE
8	1	P570051	RIBBON CABLE CHANNEL
9	1	P680850	CONTROL TRANSFORMER
10	1	P680855	MAIN TRANSFORMER
11	4	P840430	10-32x1/2 SLOTTED PAN HEAD SCREW
12	8	P840530	#10 FLAT WASHER
13	4	P840572	#10 LOCKWASHER
14	4	P840740	10-32 HEX NUT
15	4	P840523	#8 LOCKWASHER
16	16	P840520	#8 FLAT WASHER
17	6	P840523	#8 LOCKWASHER
18	1	ZP570400	PANTOGRAPH ASSY.
19	3	P520406	1/4-20x /16 T-NUT
20	3	P520408	RUBBER GROMMET
21	2	P840056	1/4-20x1 + 1/4 SOCKET HEAD CAP SCREW
22	3	P520509	NEOPREME WELL NUT
23	1	P520072	HEAD LOCKING SCREW
24	1	P520074	SPRING
25	1	P840710	1/4-20 HEX NUT
26	1	P840504	1/4 LOCK WASHER
27	1	P840745	4 PRONG BLACK
28	1	P840062	1/4-20x3 SOCKET HEAD CAP
29	5	P312027	TY-RAP
30	9 ft.	P520001	ADHESIVE FOAM 1"x7/16

PARTS IDENTIFICATION: M800

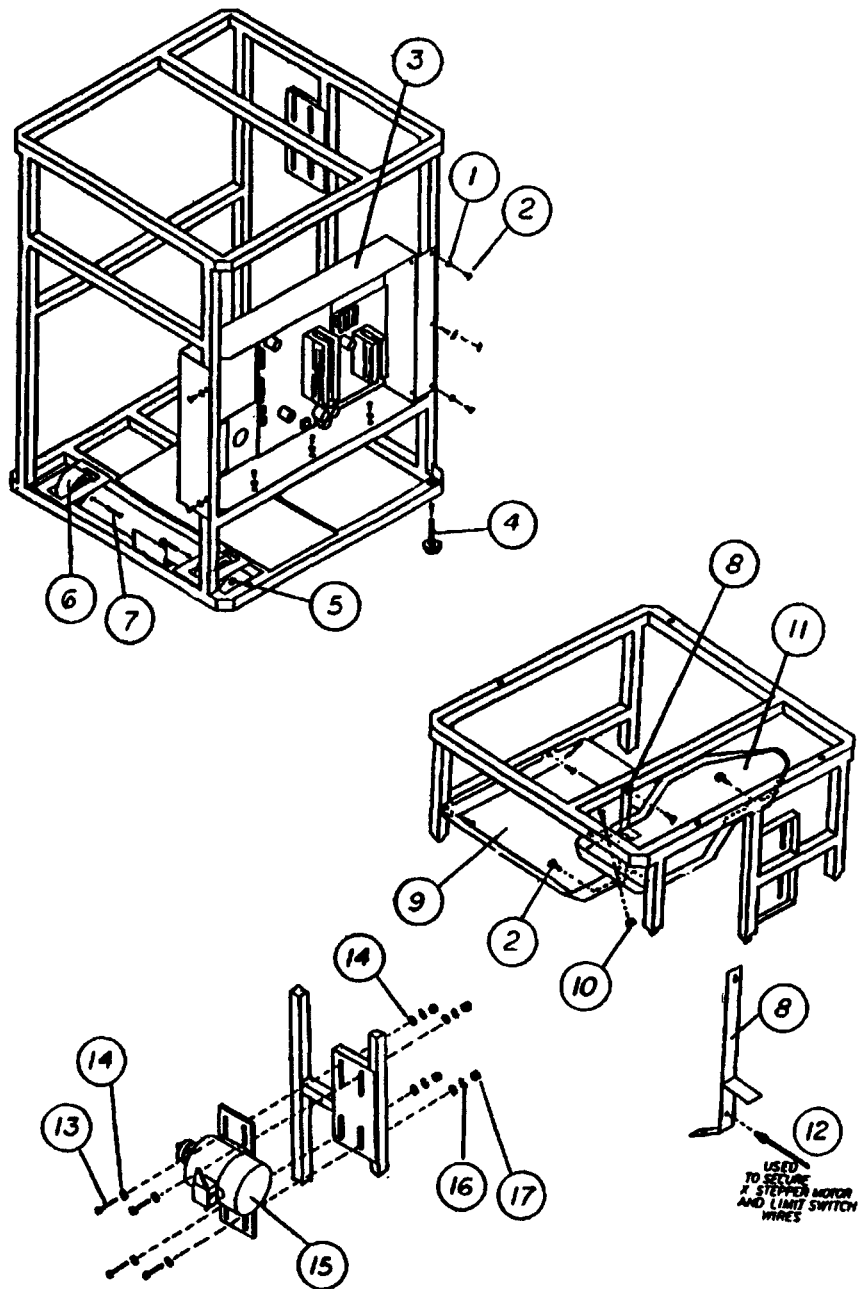

Frame Assembly 6 - fig. 6

PARTS IDENTIFICATION: M800**FRAME ASSEMBLY**

ITEM	QUANTITY	PART NO.	DESCRIPTION
1	16	P840520	#8 FLAT WASHER
2	17	P840203	#8-32x1/2 SELF TAP SCREW
3	1	XP680700	ELECTRONIC ENCLOSURE ASSEMBLY
4	2	P670802	LEVELING FOOT
5	2	P520064	LOCKNUT AXLE
6	2	P670804	WHEEL
7	2	P520066	AXLE
8	1	P520054	PAN BRACKET
9	1	P520055	PANTOGRAPH PAN (PLASTIC)
9a	1	P571055	PANTOGRAPH PAN (METAL)
10	2	P840730	8-32 HEX NUT
11	1	P520053	DRIP PAN (PLASTIC)
11a	1	P671845	DRIP PAN (METAL)
12	31	P530237	DART-TIE
13	4	P840603	3/16-18x1" HEX HEAD
14	8	P840561	5/16 FLAT WASHER
15	1	ZP580600	DC MOTOR ASSY.
16	4	P840582	5/16 LOCK WASHER
17	4	P840707	5/16 HEX NUT

PARTS IDENTIFICATION: M800

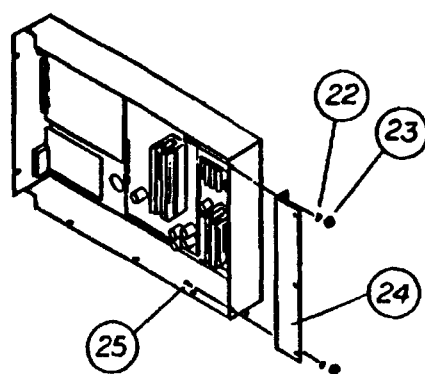
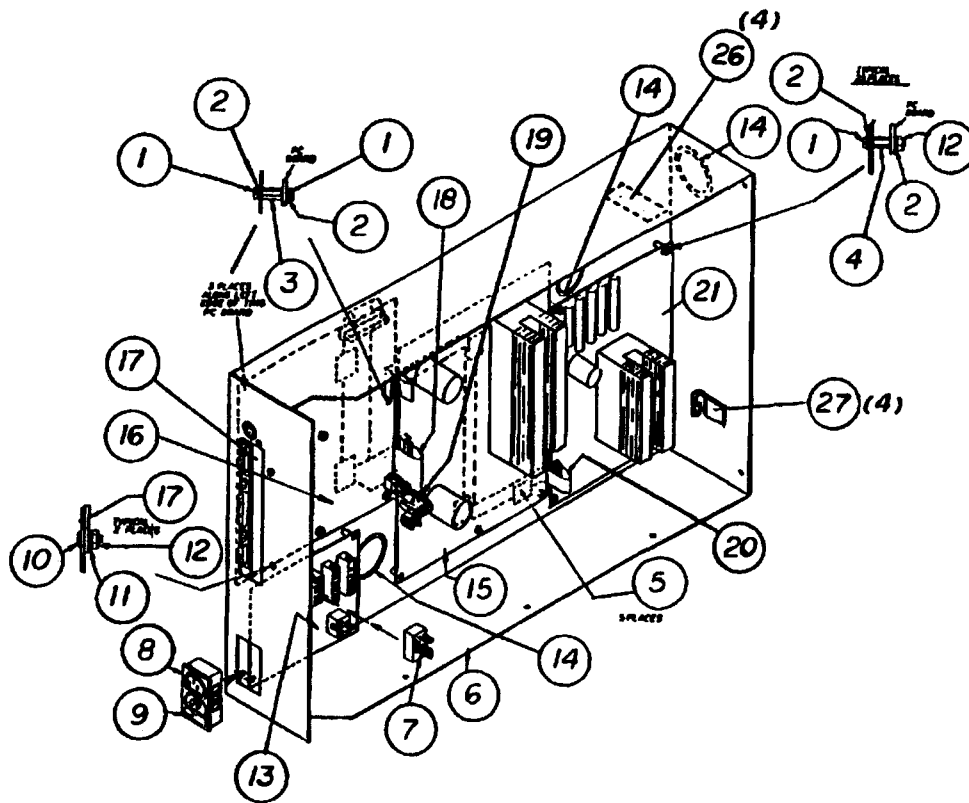

Frame Assembly 7 - fig. 7

PARTS IDENTIFICATION: M800**ELECTRONICS ENCLOSURE ASSEMBLY**

ITEM	QUANTITY	PART NO.	DESCRIPTION
1	31	P840415	6-32x1/4 SLOTTED PAN HEAD SCREW
2	54	P840511	#6 LOCK WASHER
3	4	P530132	6-32x1/4 STANDOFF
4	23	P680721	6-32x1/2 M/F STANDOFF
5	5	P520085	FLAT CABLE CLIP, ADHESIVE BACK
6	1	P670830	ELECTRONIC ENCLOSURE
7	1	P680722	110V JUMPER BLOCK
8	1	P680410	FUSED POWER CONNECTOR
9	1	P530807	5A 250V SLOW BLOW FUSE
10	2	P840410	6-32x3/8 SLOTTED PAN HEAD
11	2	P840509	#6 LOCKWASHER
12	25	P840725	6-32 HEX NUT
13	1	P680400	POWER JUNCTION PCB
14	2 ft	9P530200	GROMMET MATERIAL
15	1	P680200	CONTROL ELECTRONICS PCB
16	1	P680100	SINGLE BOARD COMPUTER PCB
17	1	P670806	DISC EXPANSION COVER PLATE
18	1	P680725	RIBBON CABLE, SBC TO CE
19	1	P680715	HARNESS SBC TO CE JUMPER
20	1	P680720	RIBBON CABLE DC DRIVE TO SBC
21	1	P680300	MOTOR DRIVE PCB
22	2	P820520	#8-FLAT WASHER
23	2	P840730	#8-32 HEX NUT
24	1	P570805	MTG BRACKET ELECTRONIC ENCLOSURE
25	2	P840156	#8-32x1/2 SLOTTED MC SCREW
26	8	P520109	RIBBON CABLE CLAMP
27	4	P670911	CABLE CLAMP STICK UP

PARTS IDENTIFICATION: M800

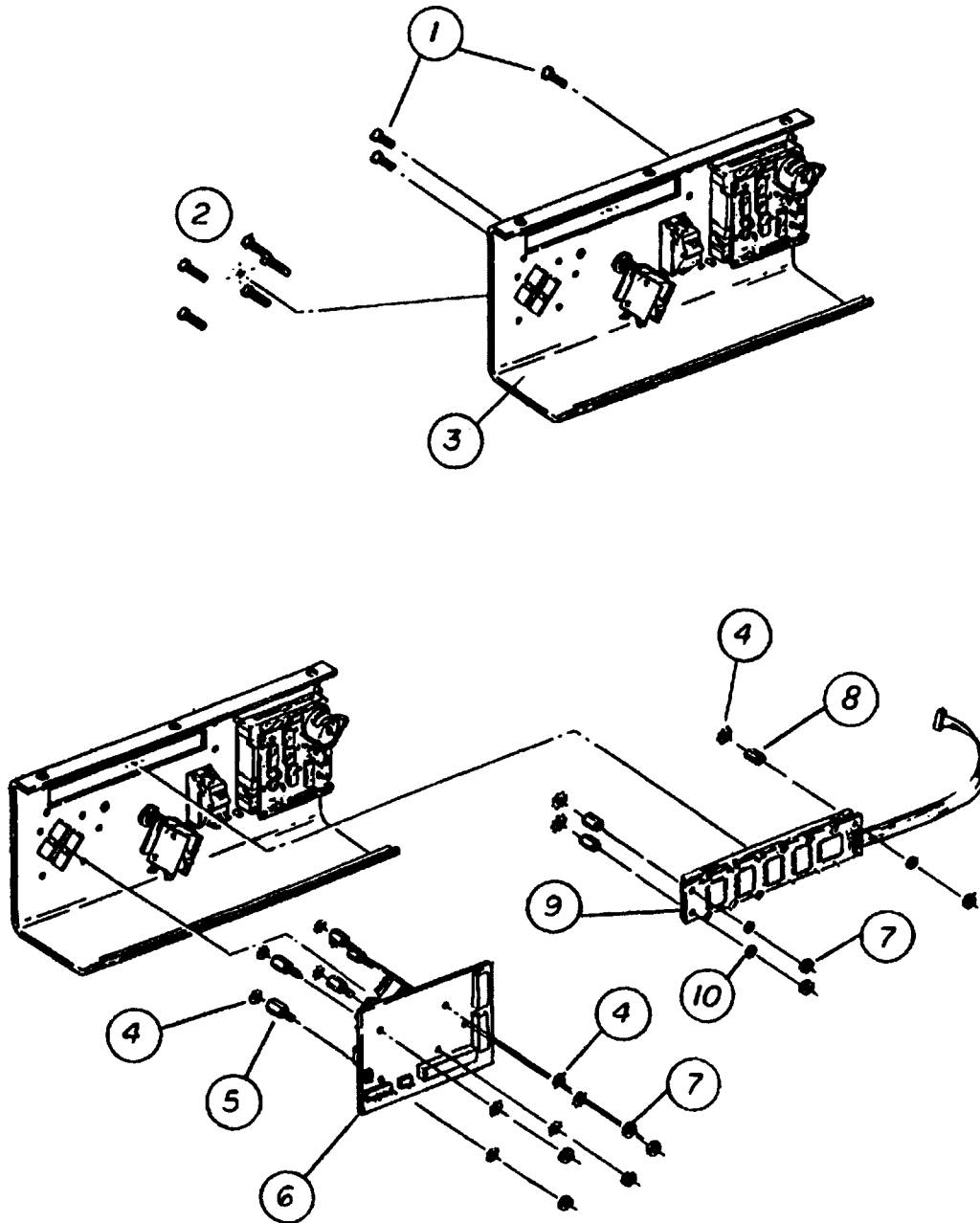

Control Console Assembly - fig. 8

PARTS IDENTIFICATION: M800**CONTROL CONSOLE ASSEMBLY**

ITEM	QUANTITY	PART NO.	DESCRIPTION
1	3	P840402	#4-40x5/8 FLAT HEAD SLOTTED
2	5	P840390	4-40x3/8 MACHINE SCREW
3-T	1	P680501	CONSOLE PANEL
3-D	1	P680515	CONSOLE PANEL
4	13	P840502	#4 EXTERNAL TOOTH WASHER
5	5	P680511	4-40x7/16 HEX STANDOFF M/F
6	1	P680510	HOOP CONTROL PCB
7	8	P840715	#4 HEX NUT
8	3	P680514	4-40x1/4 NYLON STANDOFF
9	1	ZP680550	DISPLAY ASSEMBLY
10	3	P840512	#4 NYLON

- T Indicates parts for use with machine supplied with cassette tape drive.

- D Indicates parts for use with machine supplied with disk drive.

PARTS IDENTIFICATION: M800

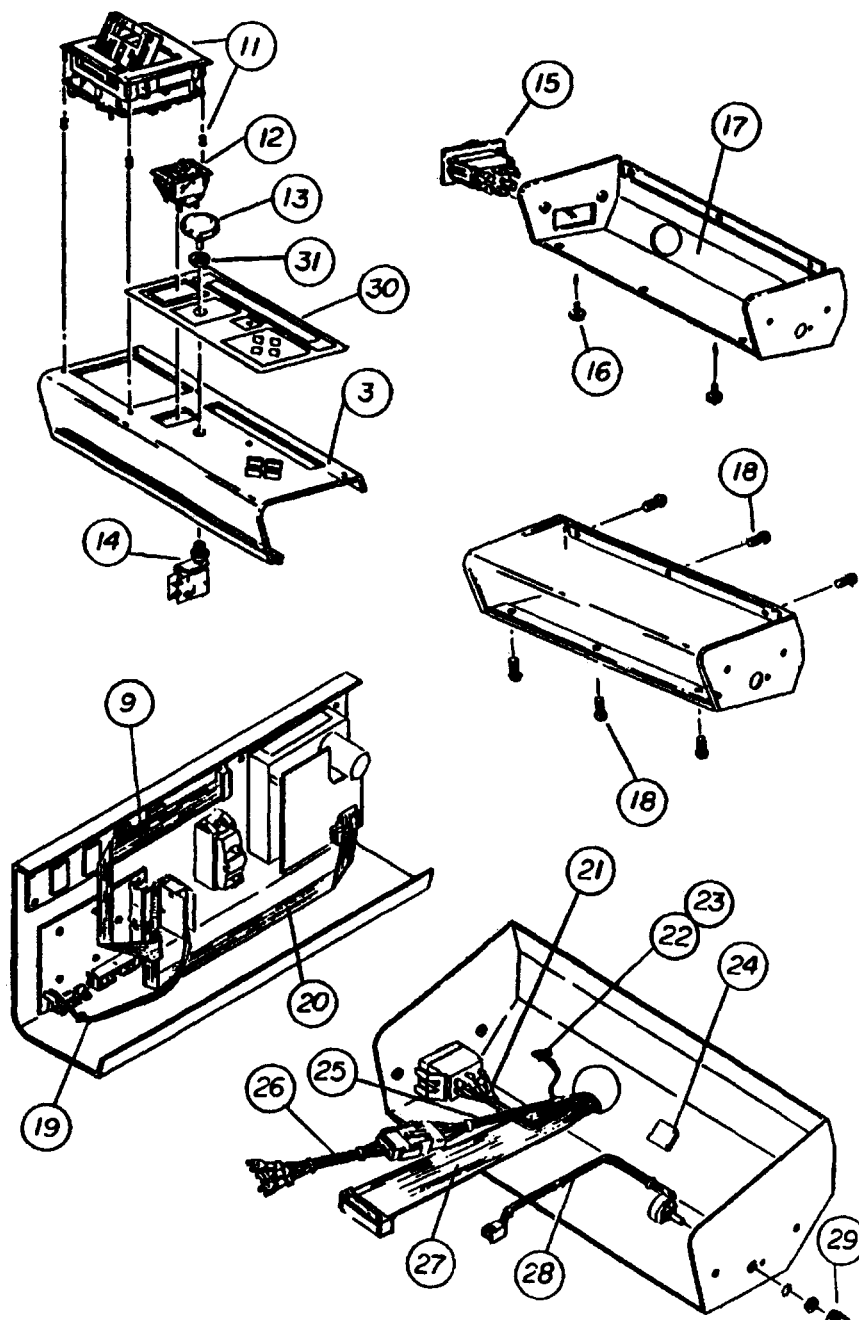

Control Console Assembly 2 - fig. 9

PARTS IDENTIFICATION: M800**CONTROL CONSOLE ASSEMBLY**

ITEM	QUANTITY	PART NO.	DESCRIPTION
3	1	P680501	CONSOLE PANEL
9	1	P680551	DISPLAY RIBBON CABLE
11-T	1	P530125	TABLE DRIVE UNIT
12	1	P680505	SWITCH, BREAKER MOTOR
13	1	P520020	RED BUTTON
14	1	P520018	STOP SWITCH
15	1	P520012	POWER SWITCH
16	2	P220501	THUMBSCREW
17	1	P680502	CONSOLE ENCLOSURE
18	6	P680512	8-32x3/8 DEC. HEAD SCREW
19	1	P680716	HARNESS, EMERGENCY STOP SWITCH
20-T	1	P680712	HOOP TO TAPE DRIVE RIBBON
20-D	1	P680728	CONNECTOR BLOCK FOR DISK
21	1	P580750	MAIN POWER SWITCH HARNESS
22	1	P580714	GROUND WIRE
23	1	P840150	6-32x1/4 PHILLIPS SCREW
24	1	P520085	RIBBON CABLE CLIP
25	1	P580710	SAFETY SWITCH HARNESS
26	1	P680711	CONSOLE SAFETY HARNESS
27	1	P580730	SBC TO CONSOLE RIBBON
28	1	P680717	VIEW ADJUST HARNESS
29	1	P680530	PLASTIC KNOB

- T Indicates parts for use with machine supplied with cassette tape drive.

- D Indicates parts for use with machine supplied with disk drive.

PARTS IDENTIFICATION: M800

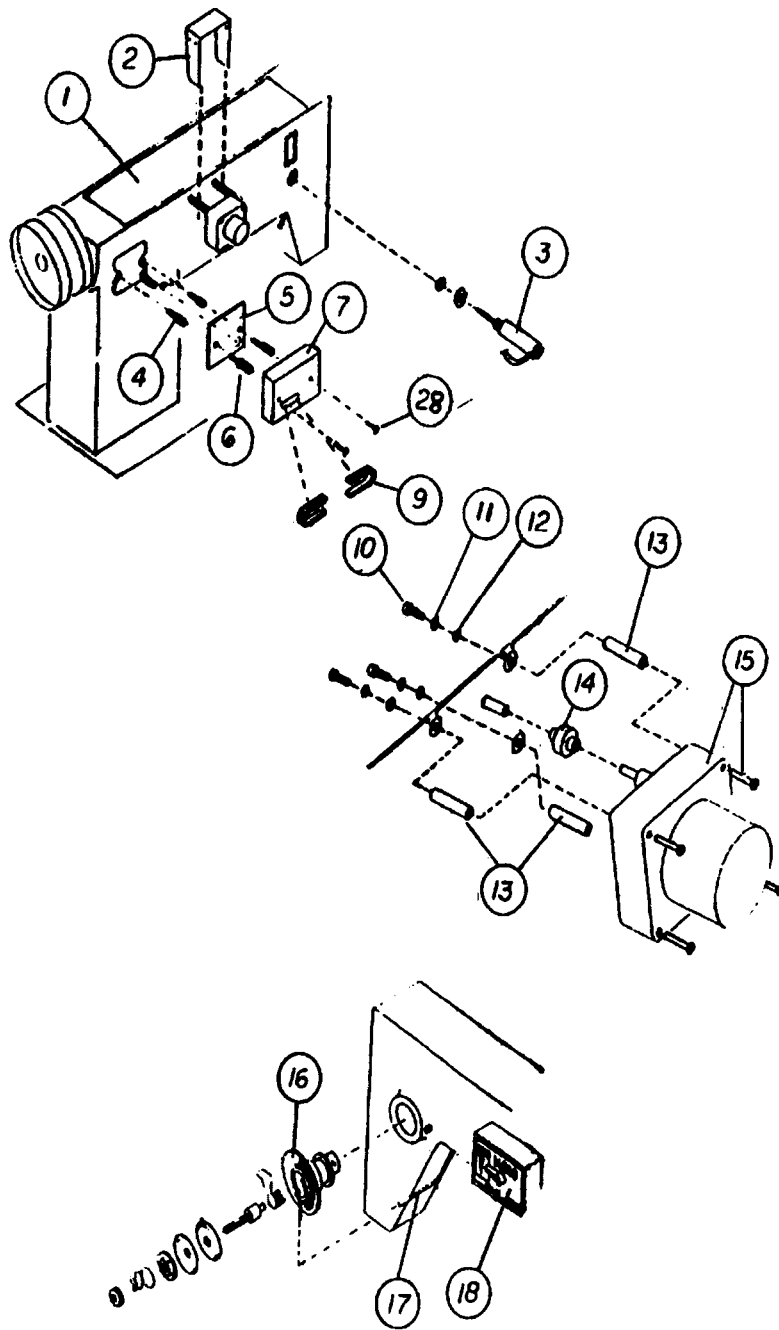

Sewing Head Assembly - fig. 10

Parts Identification - page 358

PARTS IDENTIFICATION: M800**SEWING HEAD ASSEMBLY**

ITEM	QUANTITY	PART NO.	DESCRIPTION
1	1	P515001	M800 SEWING HEAD ASSEMBLY
2	1	P515015	STITCH WIDTH MOTOR COVER
3	1	P614010	TENSION RELEASE SOLENOID
4	2	P413035	6-32x1/4 M/F STANDOFF
5	1	P680250	HEAD INTERFACE CARD
6	2	P614003	6-32x3/4 M/F STANDOFF
7	1	P614038	INTERFACE CARD COVER
8	2	P820056	CABLE CLAMP 1/8
9	4	P840410	6-32x3/8 SCREW
10	4	P840071	8-32x1" SOC HEAD
11	3	P840508	#8 LOCK WASHER
12	3	P840520	#8 FLAT WASHER
13	3	P515010	8-32x1 1/4 STANDOFF
14	1	P312013	SWITCH WIDTH MOTOR COVER
15	1	P515050	SWITCH WIDTH MOTOR ASSEMBLY
16	1	P330128	THREAD BREAK SENSOR
17	1	P514015	THREAD BREAK HARNESS
18	1	P896004	DECAL, SWITCH WIDTH M800
19	1	P840965	WIRE GUIDE
20	1	P514045	SW LIMIT PICK-UP
21	1	P413018	SW LIMIT MAGNET
22	1	P840065	8-32x3/8 SOC HEAD
23	2	P840523	#8 SPLIT LOCK WASHER
24	1	P514040	PICK UP ASSEMBLY
25	4	P840410	6-32x3/8 SCREW
26	1	P514030	PT/NPS SENDER ASSEMBLY
27	2	P840621	10-32x3/4 SOC HEAD
28	2	P840410	#6-32x3/8 FLAT HEAD SCREW
29	1	P810084	COUNTERWEIGHT RIGHT
30	1	P810082	COUNTERWEIGHT LEFT

PARTS IDENTIFICATION: M800

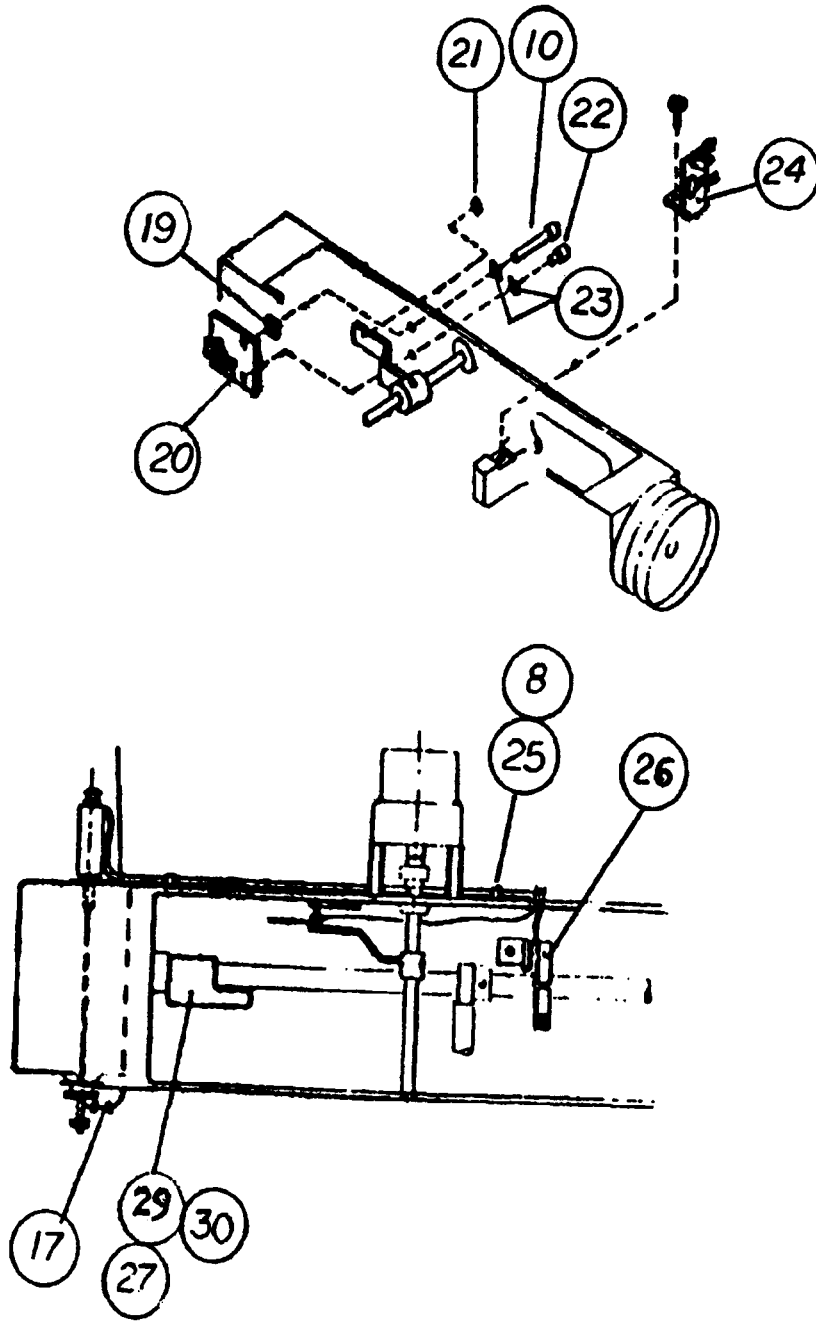

Sewing Head Assembly 2 - fig. 11

NOTES

PARTS IDENTIFICATION: M800

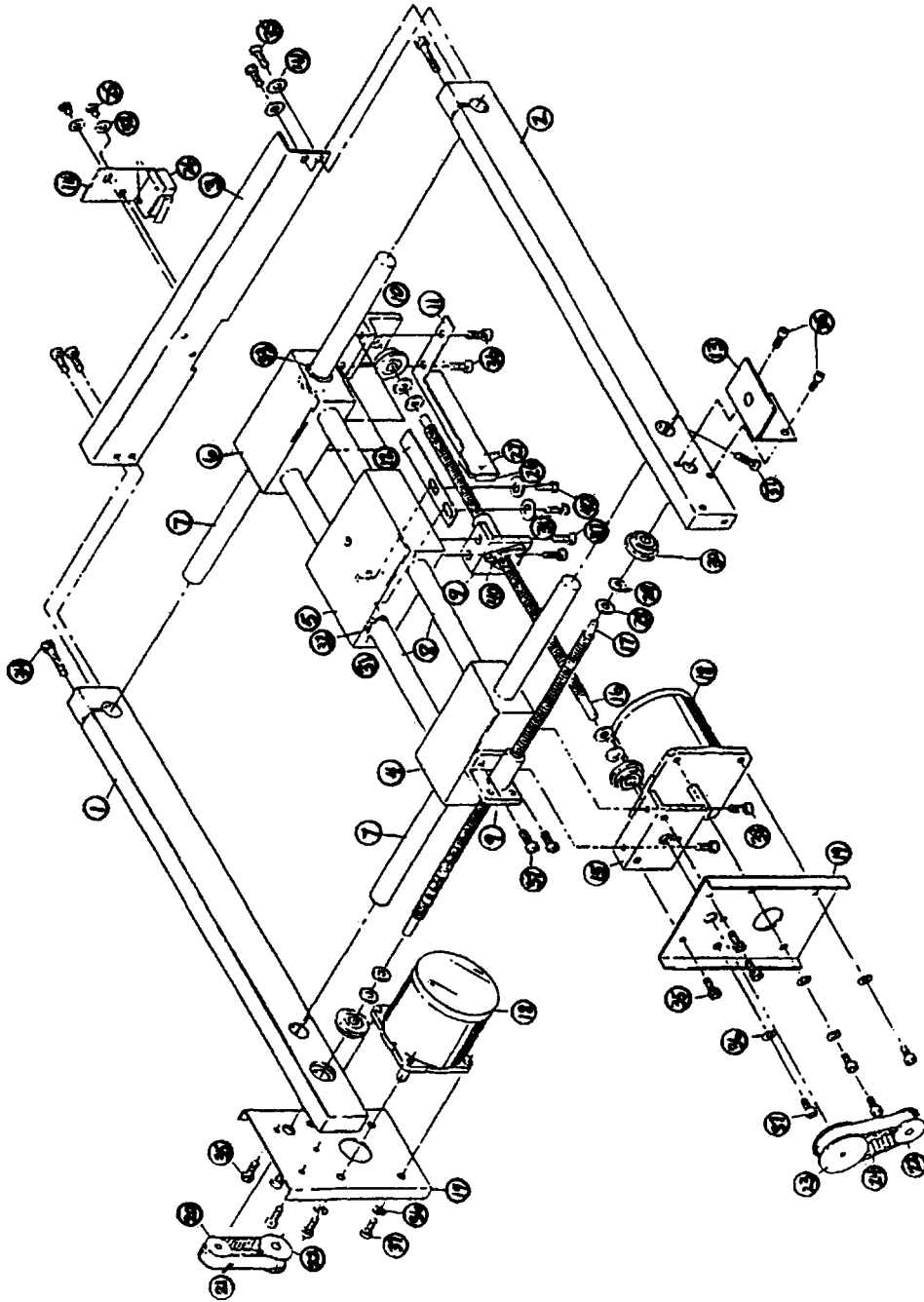

Pantograph Assembly - fig. 12

PARTS IDENTIFICATION: M800**PANTOGRAPH ASSEMBLY**

ITEM	QUANTITY	PART NO.	DESCRIPTION
1	1	P520402	FRAME BAR RIGHT
2	1	P520401	FRAME BAR LEFT
3	1	P520403	SUPPORT
4	1	P520413	BLOCK, MOTOR END
5	1	P520421	BLOCK CENTER
6	1	P521441	BLOCK FREE END
7	2	P520419	X-AXIS BAR GUIDE
8	2	P820416	Y-AXIS BAR GUIDE
9	2	P520425	SUPPORT LEAD SCREW NUT
10	1	P520439	SUPPORT LEAD SCREW
11	1	P520468	BRACKET SWITCH X-AXIS
12	1	P520466	ACTUATOR SWITCH BRACKET X-AXIS
13	1	P520437	BRACKET MOTOR MOUNT
14	1	P520464	BRACKET SWITCH Y-AXIS
15	1	P520433	SUPPORT MOUNT
16	1	P640407	LEAD SCREW Y-AXIS
17	1	P520427	LEAD SCREW X-AXIS
18	2	TC-1083	STEPPER MOTOR
19	2	P620419	MOTOR BRACKET
20	1	P520471	PULLY, SM. 5/16xL037
21	1	P520407	TIMING BELT, SM. 15xL037
22	2	P520405	PULLY, SM. 3/8 15xL037
23	1	P520409	PULLY, LG. 5/16 15xL037
24	1	P520431	TIMING BELT, LG. 30xL037
25	2	P840417	8-32x 3/16 SLOT. PAN HEAD
26	2	P520404	STITCH WIDTH
27	4	P840407	4-40x 1/2 SLOT HEAD
28	4	P520412	THRUST WASHER
29	4	P520435	SPRING WASHER
30	4	P520411	FLANGED BEARING
31	6	P520415	RETAINING RING
32	6	P520417	NYLON BUSHING

PARTS IDENTIFICATION: M800**PANTOGRAPH ASSEMBLY (Continued)**

ITEM	QUANTITY	PART NO.	DESCRIPTION
33	2	P520423	BALL BUSHING
34	2	P840056	1/2-20x 3/8 SOC HEAD SCREW
35	12	P840049	1/4-20x 3/8 SOC HEAD SCREW
36	8	P840580	1/4 SPLIT WASHER
37	14	P840052	1/4-20x 1/2
38	4	P840077	5/16-18x1 1/2 SOC HEAD SCREW
39	2	P840530	#10 FLAT WASHER
40	8	P840073	10-32x 3/8 SOC HEAD SCREW
41	2	P840540	1/4 FLAT WASHER
42	2	P840520	#8 FLAT WASHER

NOTES

PARTS IDENTIFICATION: M800

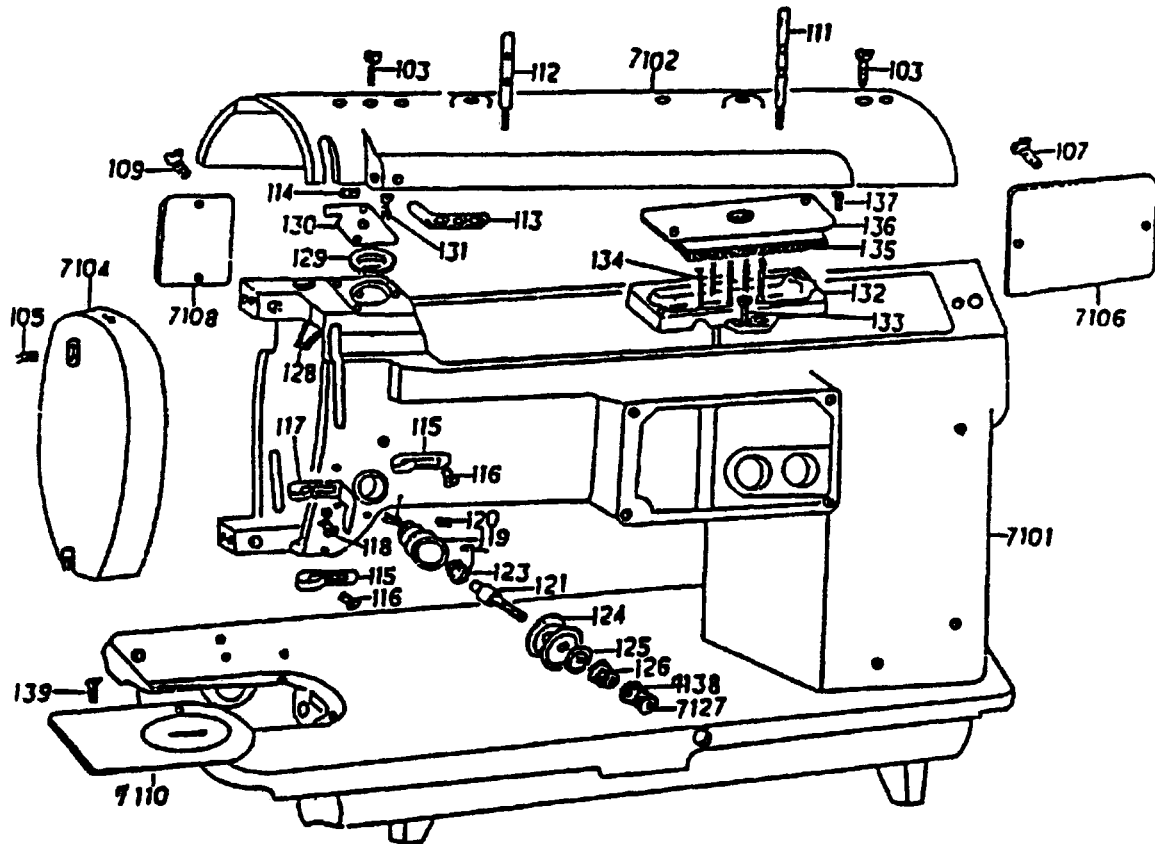

Main Frame and Cover Assembly - fig. 13

PARTS IDENTIFICATION: M800**MAIN FRAME AND COVER ASSEMBLY**

ITEM	QUANTITY	PART NO.	DESCRIPTION
7101	1	P517101	ARM BED
7102	1	P517102	TOP COVER
103	2	P312103	SCREW
7104	1	P517104	FACE PLATE
105	1	P312105	SCREW
7106	1	P517106	ARM SIDE COVER (LARGE)
107	2	P312107	SCREW
7108	1	P517108	ARM SIDE COVER (SMALL)
109	2	P312109	SCREW
7110	1	P517110	NEEDLE PLATE
111	1	P312111	THREAD GUIDE (4 HOLE)
112	1	P312112	THREAD GUIDE (2 HOLE)
113	1	P312113	THREE HOLE THREAD EYELET
114	1	P312114	SCREW
115	2	P312115	ARM THREAD GUIDE (UPPER & LOWER)
116	2	P312116	SCREW
117	1	P312117	TENSION POST THREAD GUIDE
118	1	P312118	SCREW
119	1	P312119	TENSION POST ROCKET
120	1	P312120	SCREW
121	1	P312121	TENSION POST
122	1	P312122	SCREW
123	1	P312123	TAKE UP SPRING
124	2	P312124	TENSION DISK
125	1	P312125	TENSION RELEASE WASHER
126	1	P312126	TENSION SPRING
7127	1	P517127	TENSION NUT
128	1	P312128	RESERVOIR (FRONT) OIL WICK
129	1	P312129	OIL PAD
130	1	P312130	RESERVOIR (FRONT) COVER PLATE
131	2	P312131	SCREW
132	1	P312132	OIL RESERVOIR (REAR)

PARTS IDENTIFICATION: M800**MAIN FRAME AND COVER ASSEMBLY (Continued)**

<u>ITEM</u>	<u>QUANTITY</u>	<u>PART NO.</u>	<u>DESCRIPTION</u>
133	2	P312133	SCREW
134	1	P312134	OIL WICK
135	1	P312135	OIL PAD
136	1	P312136	COVER PLATE
137	2	P312137	SCREW
7138	1	P517138	WASHER FOR TENSION NUT
7139	1	P517139	NEEDLE PLATE SET SCREW

NOTES

PARTS IDENTIFICATION: M800

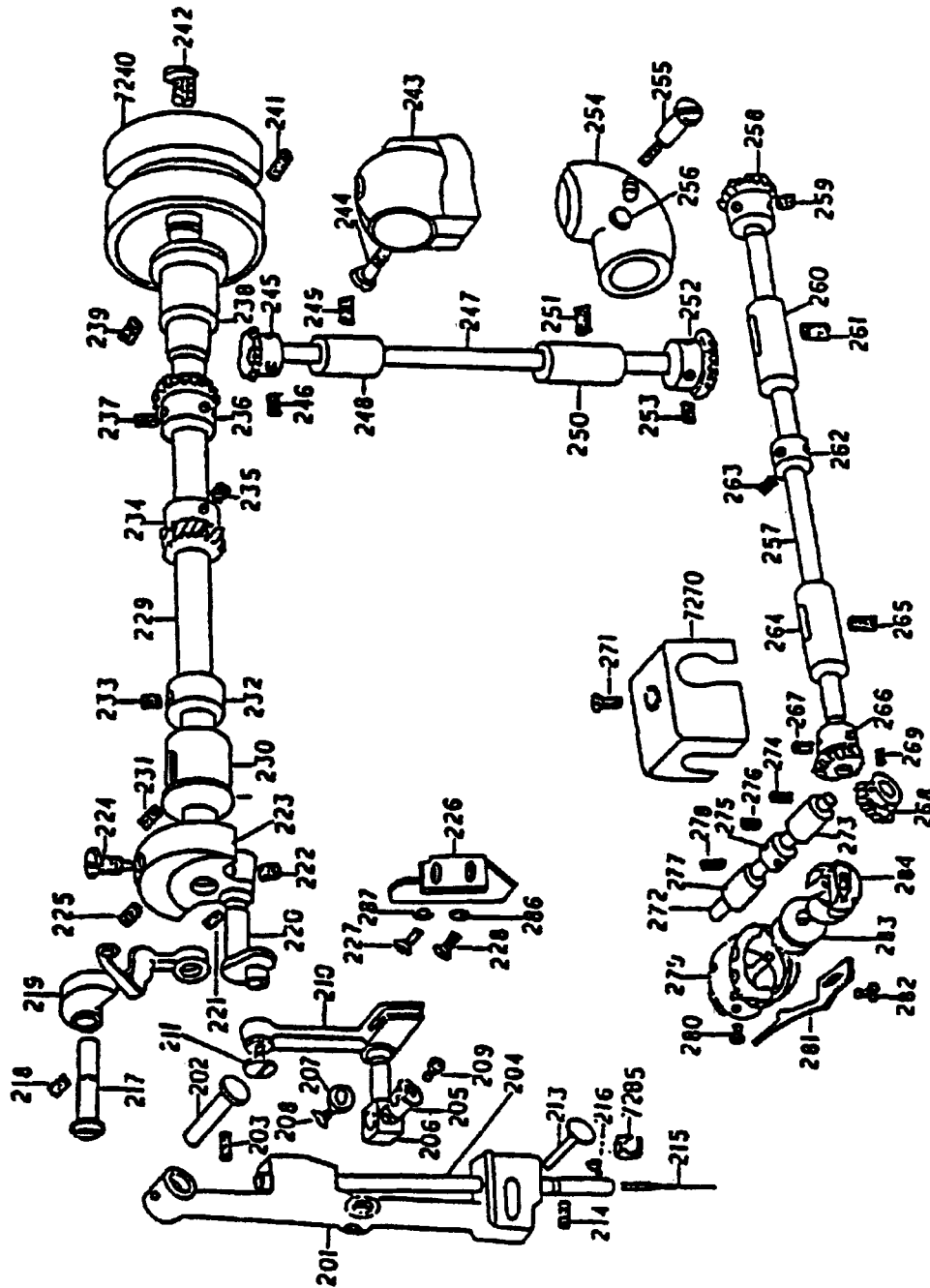

Needle Bar and Hook Drive Shaft Components - fig. 14

PARTS IDENTIFICATION: M800**NEEDLE BAR AND HOOK DRIVE ASSEMBLY**

ITEM	QUANTITY	PART NO.	DESCRIPTION
201	1	P312201	NEEDLE BAR FRAME
202	1	P312202	HINGE PIN
203	1	P312203	SCREW
204	1	P312204	NEEDLE BAR
205	1	P312205	NEEDLE BAR CONNECTING STUD
206	1	P312206	BUSHING
207	1	P312207	WASHER
208	1	P312208	SCREW
209	1	P312209	NEEDLE BAR SET SCREW
210	1	P312210	NEEDLE BAR CONNECTING LINK
211	1	P312211	SCREW
213	1	P312213	NEEDLE BAR FRAME GUIDE PIN
214	1	P312214	SCREW
215	1	P312215	NEEDLE
216	1	P312216	NEEDLE SET SCREW
217	1	P312217	TAKE-UP LEVER HINGE PIN
218	1	P312218	SCREW
219	1	P312219	TAKE-UP LEVER WITH CAM
220	1	P312220	NEEDLE BAR CRANK
221	1	P312221	SCREW (LARGE)
222	1	P312222	SCREW (SMALL)
223	1	P312223	COUNTERWEIGHT
224	1	P312224	SCREW (LARGE)
225	1	P312225	SCREW (SMALL)
226	1	P312226	NEEDLE BAR CONNECT LINK GUIDE PLATE
227	1	P312227	SCREW (UPPER)
228	1	P312228	SCREW (LOWER)
229	1	P312229	ARM SHAFT
230	1	P312230	BUSHING (FRONT)
231	1	P312231	SCREW
232	1	P312232	ARM SHAFT COLLAR
233	2	P312233	SCREW
234	1	P312234	NEED VIBRATION PINION (SPIRAL)

PARTS IDENTIFICATION: M800**NEEDLE BAR AND HOOK DRIVE ASSEMBLY (Continued)**

ITEM	QUANTITY	PART NO.	DESCRIPTION
235	2	P312235	SCREW
236	1	P312236	ARM SHAFT (HORIZONTAL) LEVEL GEAR
237	2	P312237	SCREW
238	1	P312238	ARM SHAFT BUSHING (REAR)
239	2	P312239	SCREW
7240	1	P517240	HANDWHEEL
241	2	P312241	SCREW
242	1	P312242	POSITIONING SCREW
243	1	P312243	GEAR AND PINION CASE
244	1	P312244	SCREW
245	1	P312245	PINION
246	1	P312246	SCREW
247	1	P312247	UPRIGHT SHAFT
248	1	P312248	BUSHING (UPPER)
249	1	P312249	SCREW
250	1	P312150	BUSHING (LOWER)

PARTS IDENTIFICATION: M800**HEAD ASSEMBLY (Continued)**

ITEM	QUANTITY	PART NO.	DESCRIPTION
251	1	P312251	SCREW
252	1	P312252	MITER GEAR
253	2	P312253	SCREW
254	1	P312254	MITER GEAR CASE
255	1	P312255	SCREW
256	1	P312256	OIL PLUG SCREW
257	1	P312257	HOOK DRIVE SHAFT
258	1	P312258	MITER GEAR (RING)
259	1	P312259	SCREW
260	1	P312260	HOOK DRIVE SHAFT BUSHING (RIGHT)
261	1	P312261	SCREW
262	1	P312262	HOOK DRIVE SHAFT THRUST COLLAR
263	2	P312263	SCREW
264	1	P312264	HOOK DRIVE SHAFT BUSHING (LEFT)
265	1	P312265	SCREW
266	1	P312266	HOOK DRIVE SHAFT HELICAL GEAR (RIGHT)
267	2	P312267	SCREW
268	1	P312268	HELICAL GEAR (LEFT)
269	2	P312269	SCREW
7270	1	P517270	HELICAL GEAR COVER
271	1	P312271	SCREW
272	1	P312272	HOOK SHAFT
273	1	P312273	BUSHING (FRONT)
274	1	P312274	SCREW
275	1	P312275	HOOK SHAFT THRUST COLLAR
276	2	P312276	SCREW
277	1	P312277	HOOK SHAFT BUSHING (REAR)
278	1	P312278	SCREW
279	1	P312279	HOOK
280	3	P312280	SCREW
281	1	P312281	BOBBIN CASE POSITION FINGER
282	1	P312282	SCREW
283	1	P312283	BOBBIN
284	1	P312284	BOBBIN CASE
7285	1	P517285	NEEDLE BAR THREAD GUIDE

PARTS IDENTIFICATION: M800

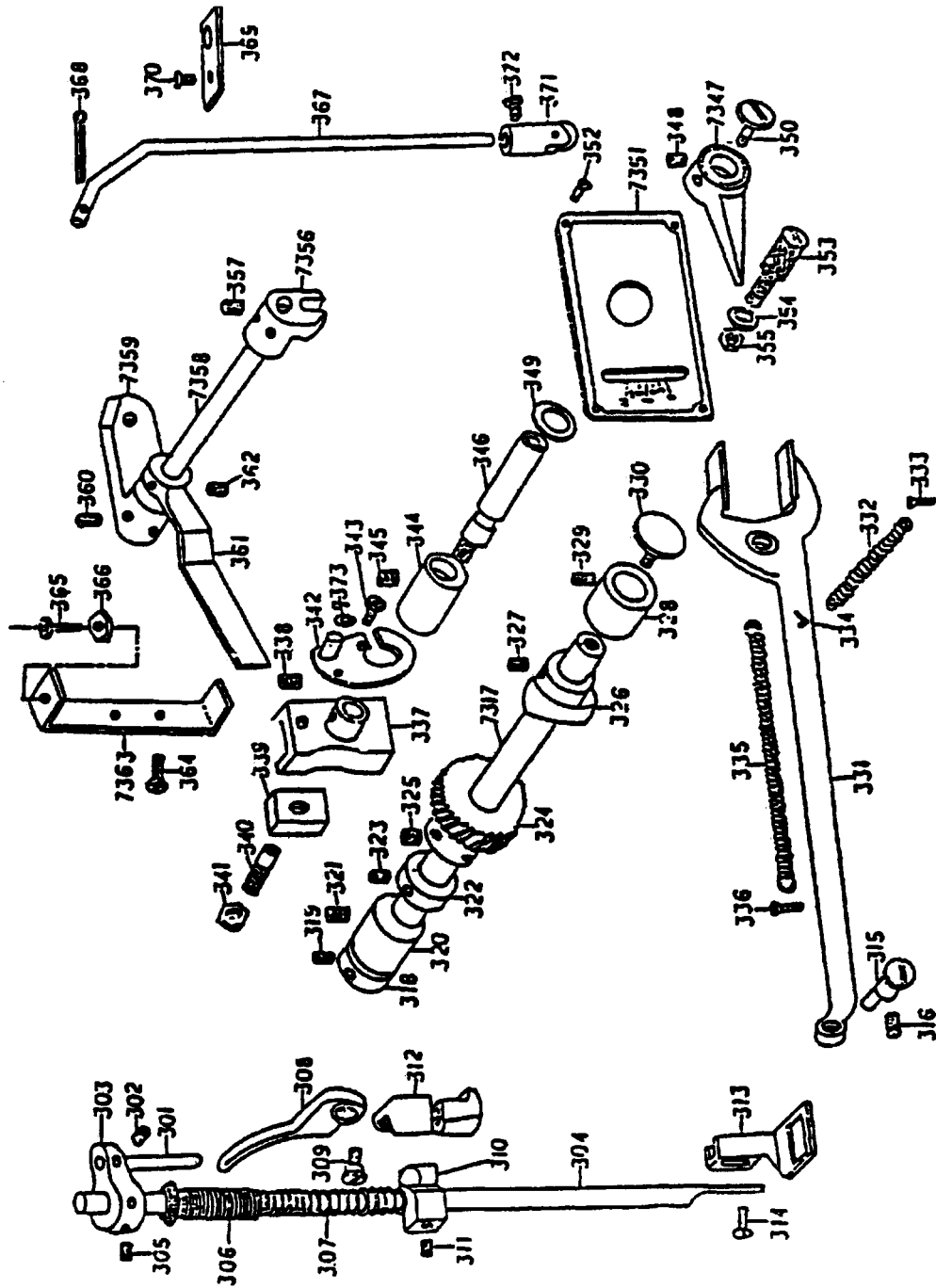

Zigzag Width Regulating Components & Presser Bar - fig. 15

PARTS IDENTIFICATION: M800**ZIGZAG WIDTH REGULATING COMPONENTS AND PRESSER BAR ASSEMBLY**

<u>ITEM</u>	<u>QUANTITY</u>	<u>PART NO.</u>	<u>DESCRIPTION</u>
301	1	P312301	PRESSER BAR LIFTING STUD FOR CAM
302	2	P312302	SCREW
303	1	P312303	PRESSER BAR LIFTING STUD HOLDER
304	1	P312304	PRESSER BAR
305	2	P312305	SCREW
306	1	P312306	PRESSER BAR LIFTER SCREW
307	1	P312307	PRESSER SPRING
308	1	P312308	PRESSER BAR LIFTER LEVER
309	1	P312309	SCREW
310	1	P312310	PRESSER BAR GUIDE BRACKET
311	1	P312311	SCREW
312	1	P312312	PRESSER BAR LEVER RELEASING BRKT
313	1	P312313	PRESSER FOOT
314	1	P312314	SCREW
315	1	P312315	ECCENTRIC STUD
316	1	P312316	SCREW
7317	1	P312317	NEEDLE VIBRATING CAM SHAFT
318	1	P312318	COLLAR (REAR)
319	2	P312319	SCREW
320	1	P312319	NDL VIBRATING CAM SHAFT BUSHING (rear)
321	1	P312321	SCREW
322	1	P312322	NDL VIBRATING CAM SHAFT BUSHING (FRON
323	1	P312323	SCREW
324	1	P312324	NDL VIBRATING CAM SHAFT BEVEL GEAR
325	2	P312325	SCREW
326	1	P312326	NEEDLE VIBRATING CAM
327	1	P312327	SCREW
328	1	P312328	CAM SHAFT BUSHING (FRONT)
329	1	P312329	SCREW
330	1	P312330	CAM SHAFT SCREW
331	1	P312331	NEEDLE BAR FRAME PIT MAN
332	1	P312332	SPRING (SMALL)
333	1	P312333	SCREW

PARTS IDENTIFICATION: M800**ZIGZAG WIDTH REGULATING COMPONENTS AND PRESSER BAR ASSEMBLY
(Continued)**

ITEM	QUANTITY	PART NO.	DESCRIPTION
334	1	P312334	SPRING HOOK
335	1	P312335	LIFTING SPRING
336	1	P312336	CATCHER SCREW
337	1	P312337	ZIGZAG REGULATOR
338	1	P312338	SCREW
339	1	P312339	SLIDE BLOCK
340	1	P312340	STUD
341	1	P312341	NUT
342	1	P312342	HOLDER
343	1	P312343	SCREW
344	1	P312344	ZIGZAG REGULATOR BUSHING
345	1	P312345	SCREW
346	1	P312346	ZIGZAG REGULATOR SHAFT
7347	1	P517347	INDICATOR
348	1	P312348	SCREW
329	1	P312349	WASHER
350	1	P312350	END SCREW
7351	1	P517351	ZIGZAG INDICATOR PLATE
352	4	P312352	SCREW
353	2	P312353	STOPPER
354	2	P312354	WASHER
355	2	P312355	NUT
7356	1	P517356	ZIGZAG CONNECTOR
357	2	P312357	SCREW
7358	1	P517358	LIFTING CRANK SHAFT
7359	1	P517359	LIFTING CRANK
360	2	P312360	SCREW
361	1	P312361	INDICATOR STOP LEVER
362	1	P312362	SCREW
7363	1	P517363	BRACKET
364	2	P312364	SCREW
365	1	P312365	ADJUSTING SCREW
366	1	P312366	NUT

PARTS IDENTIFICATION: M800**ZIGZAG WIDTH REGULATING COMPONENTS AND PRESSER BAR ASSEMBLY
(Continued)**

ITEM	QUANTITY	PART NO.	DESCRIPTION
367	1	P312367	LIFTING ROD
368	1	P312368	COTTER PIN
369	1	P312369	STABILIZE PLATE
370	1	P312370	SCREW
371	1	P312371	LIFTING ROD ROLLER
372	1	P312372	SCREW
7373	1	P517373	WASHER FOR 343

NOTES

Parts Identification - page 378